

RootSpace® Installation Instructions

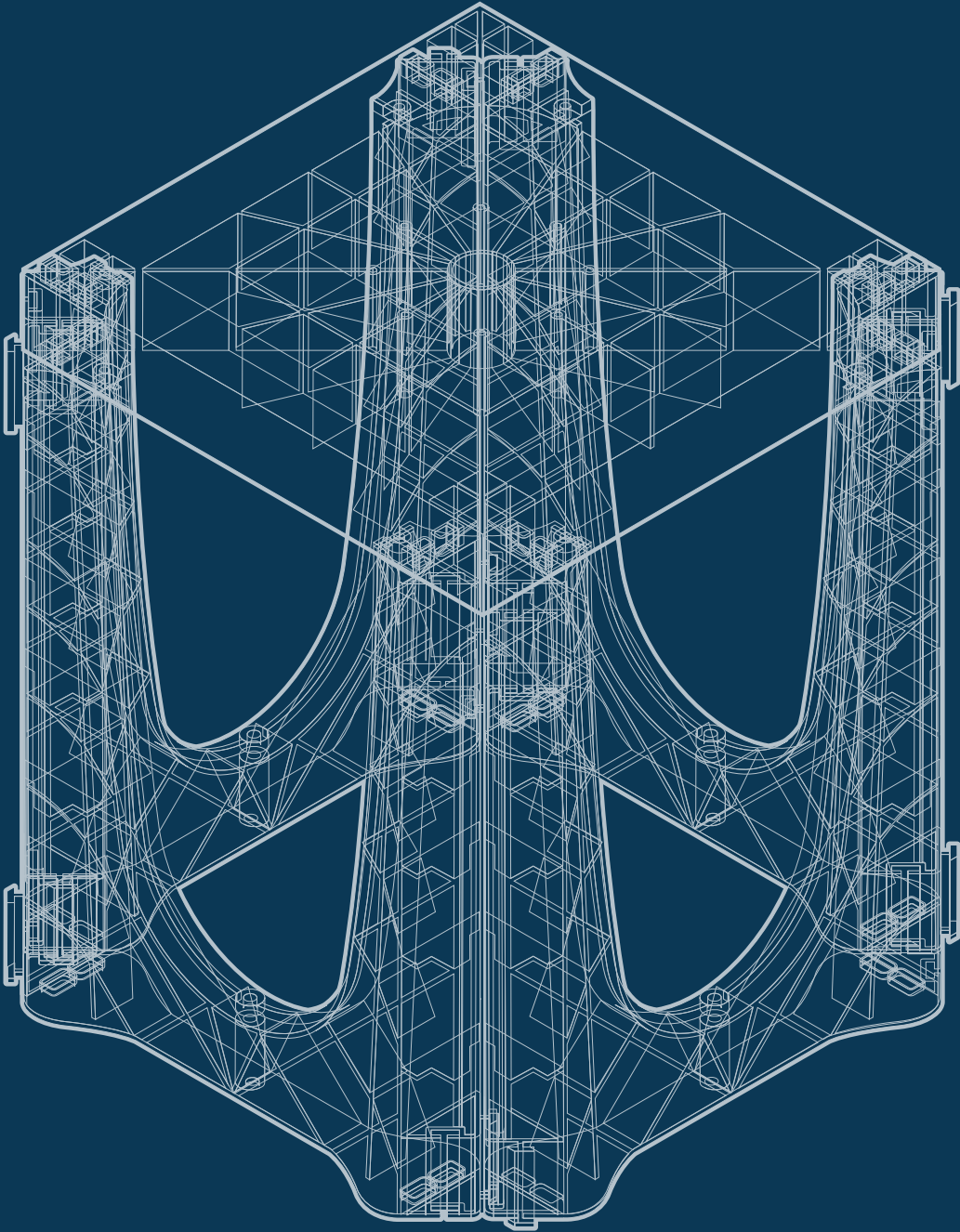

RootSpace® Pavement Support System

These instructions show the recommended installation procedure for GreenBlue Urban's RootSpace® Pavement Support System.

Each unit is made of two components, AirFlow™ Lid and Upright with the option of a Infill Panel. When joining more than one unit together each unit will share a common Upright.

Parts

A Upright x 4

B AirFlow™ Lid

C Infill Panel (Optional)

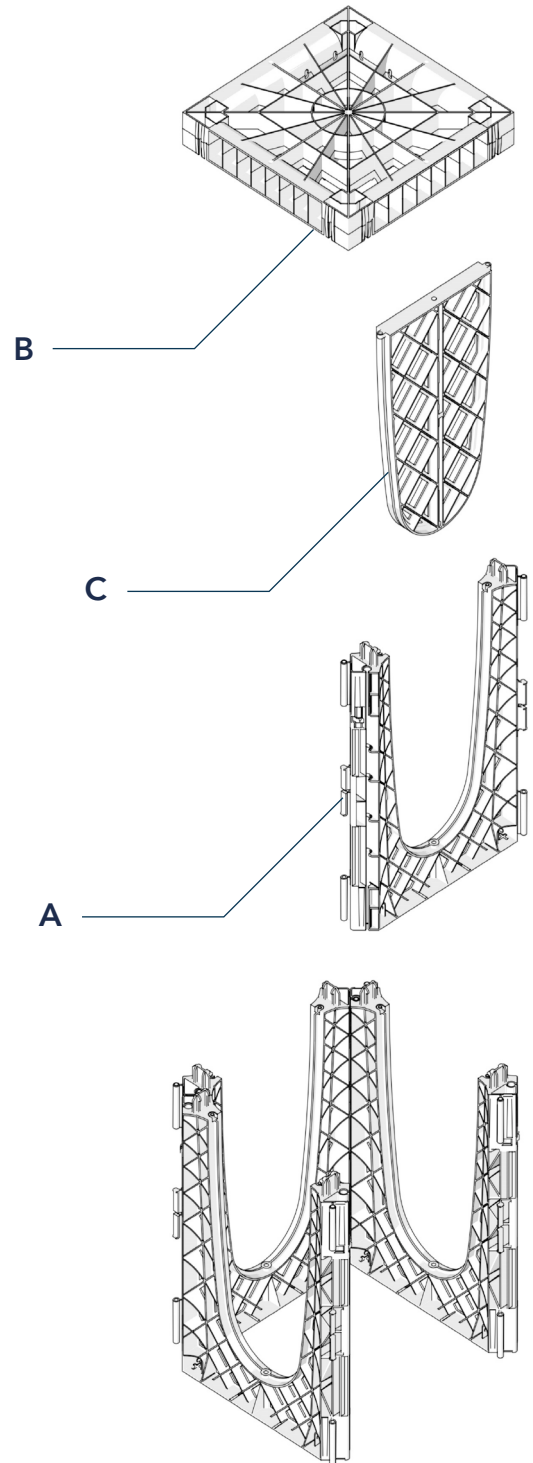

DOWNLOAD

ArborSystem® Installation & Maintenance Manual

For full instructions on how to install the complete ArborSystem® tree pit package please refer to our guide.

greenblue.com/resources



RootSpace® Pavement Support System

Tree Pit Excavation Depth

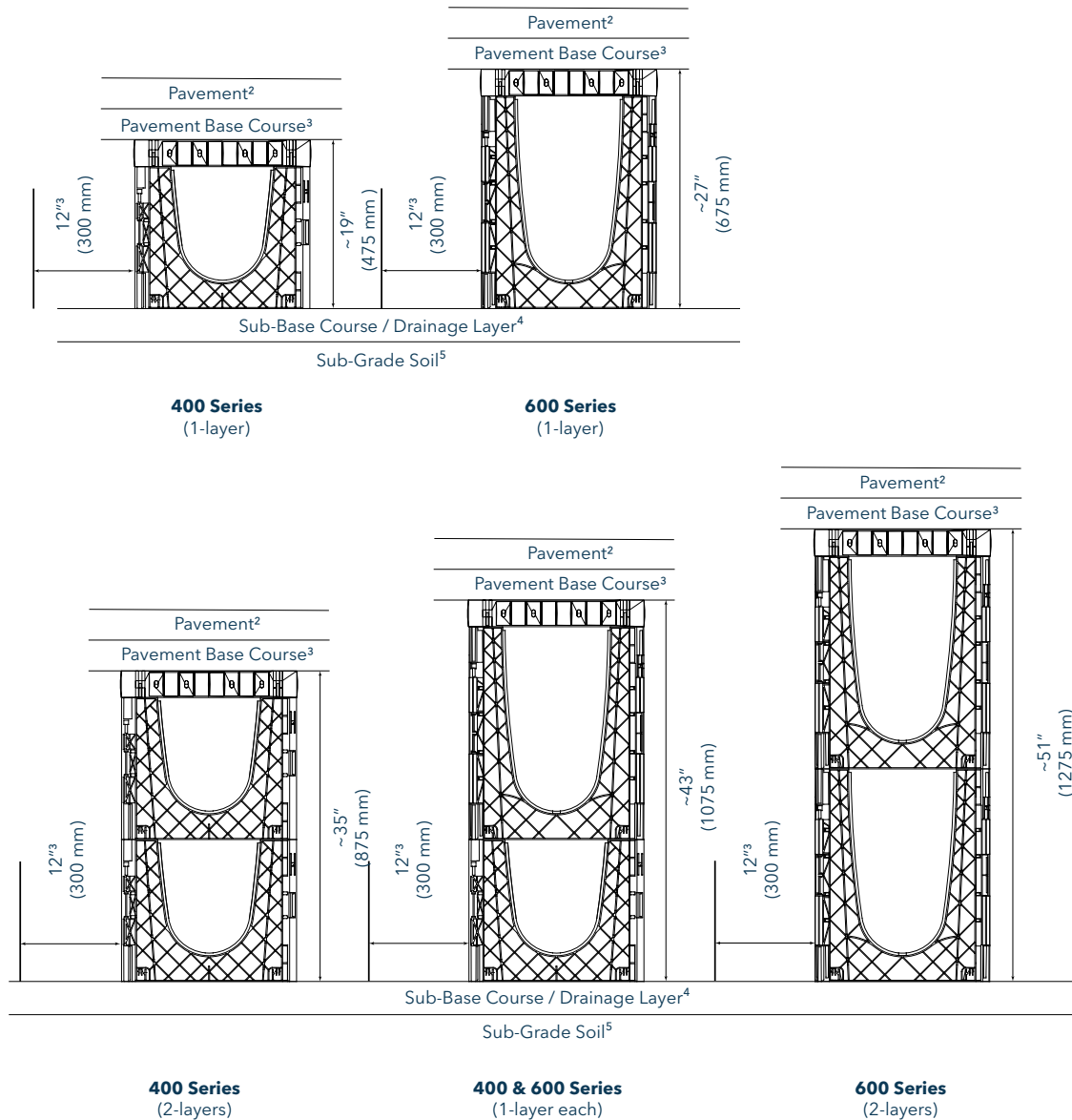

Notes

1. Pavement design per engineers specifications.
2. Pavement base course per engineers specifications. 4" (100 mm) minimum depth of a compactable angular aggregate placed on top of a geogrid with an integrated geocomposite. Compact base course to a minimum of 95% standard proctor density.
3. Excavate a minimum of 12" (300 mm) beyond the perimeter of the RootSpace® Pavement Support System to allow for proper backfill and compaction. Compact backfill to a minimum of 95% standard proctor density.
4. Total excavation depth is a sum of the RootSpace® Pavement Support System height, plus the thicknesses of the sub-base course/drainage layer, the base course and the pavement.
5. Sub-base course/drainage layer per engineers specifications. 4" (100 mm) minimum depth of a compactable angular aggregate, placed on a geogrid or filter fabric, based on project design requirements. Compact sub-base/drainage layer to a minimum of 95% standard proctor density.
6. For sub-grade soils with an allowable bearing capacity of less than 2000 psf (96 kPa), a geotechnical engineer should evaluate the specific conditions.

RootSpace® Pavement Support System

Tree Pit Excavation Area

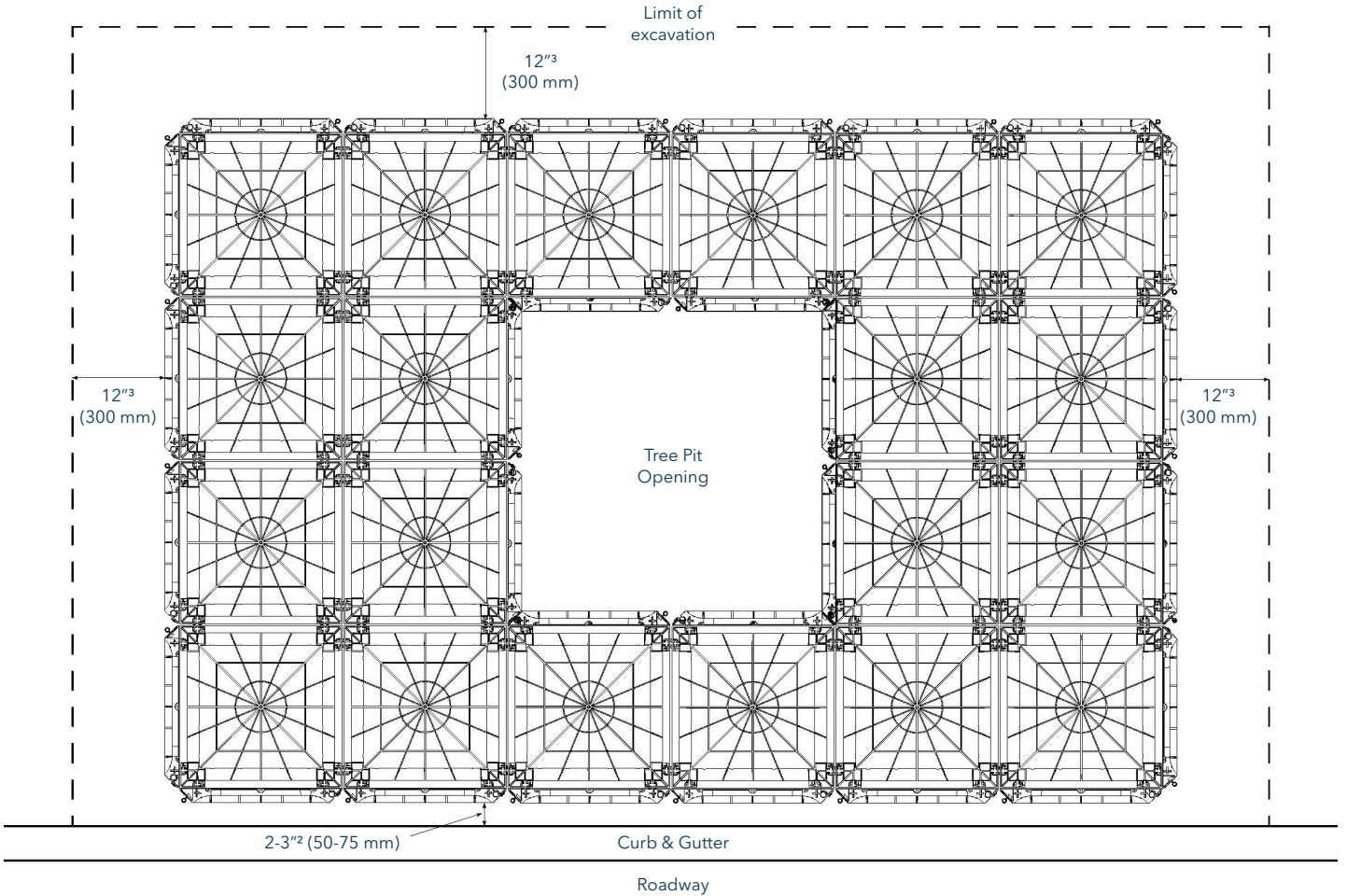

Notes

1. Excavate a minimum of 12" (300 mm) beyond the perimeter of the RootSpace® Pavement Support System to allow for proper backfill and compaction. Compact backfill around the perimeter to a minimum of 95% standard proctor density
2. Allow a maximum of 2-3" (50-75 mm) between the back of the curb and the RootSpace® Pavement Support System to allow for proper backfill and compaction. Backfill the space between the back of the curb and the RootSpace® Pavement Support System using sand, aggregate fines or non-shrink grout, and compact to a minimum of 95% standard proctor density.

Note:

When calculating the overall system dimensions, add 2" to each of the outside edges to account for the system uprights below.

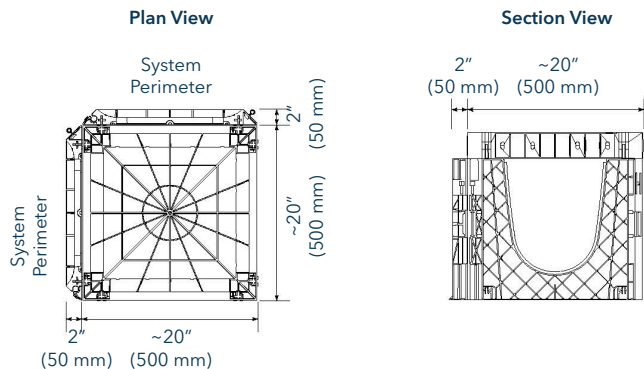

Assembly of RootSpace® Pavement Support System

- Determine whether the tree pit(s) is an interconnected assembly (typical method) or consists of independent module layout - see specification and layout details. If layout contains independent module assembly, request a copy of the separate "RootSpace® Independent Assembly Installation Instructions" for installation details specific to independent assembly.
- Identify tree location by marking out the inner dimensions of the tree pit opening. This area remains void of the RootSpace® Pavement Support System in a single layer application.
- Each unit is mainly made up of two components, AirFlow™ Lid and Upright Panel (with the option of an Infill Panel for increased lateral stability). When joining more than one unit together each unit will share a common upright Panel.
- Joining two Upright Panels: First engage lower tab into slot, then align top tab into top slot. Push unit down until the panels lock into place. Continue this process across the entire excavation. Do not install upright Panels in the top layer of the tree pit openings.
- Multi-Layer System: Place Upright Panel directly over the lower Upright Panel and push unit downward until it locks in the top layer at the tree pit opening. Continue this process across the entire lower level. Do not install Upright Panels in the tree pit openings. If assembling a multi-layer system, see specifications and layout details to determine whether bottom layer(s) of tree pit opening requires placement of RootSpace® modules.
- Installing optional Infill Panels: Locate male and female guides and slide panel down. Ensure panel pins locate top (2) and base (1) lock into place.
- Installing AirFlow™ Lid: Locate the AirFlow™ Lid over the tabs on the Upright Panel and push down until the AirFlow™ Lid locks in place. Before installing AirFlow Lids, determine which method of soil filling will be used (see section 4.3 for details).
- Before filling with soil, install single row of AirFlow™ Lids around the perimeter and throughout the center at a minimum of every three rows, in a 'ladder' formation, to ensure construction is square.
- Utilities within the RootSpace® Pavement Support System should meet specifications as required by utility company's standards. This may require special treatments, barriers and details to achieve this - see "Utilities & RootSpace® Guide" for more details.
- The RootSpace® Pavement Support System should not be left exposed to extreme temperatures, high wind conditions, snow, ice or copious amounts of rainfall.

1 Joining two Uprights A

Engage lower tab into slot and push the unit straight down until both tabs are locked into position.

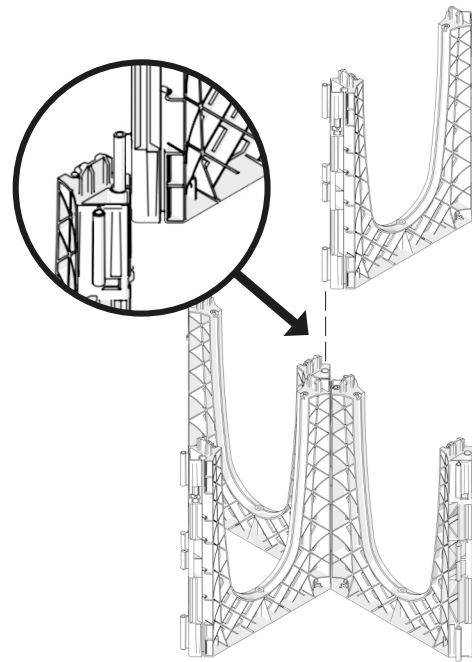

2 Installing optional Side Panel C

Before installing the AirFlow™ Lid, you will need to install the optional Side Panel if required. Locate male and female guides and slide panel down. Ensure panel pins locate x2 top and x1 base with a click.

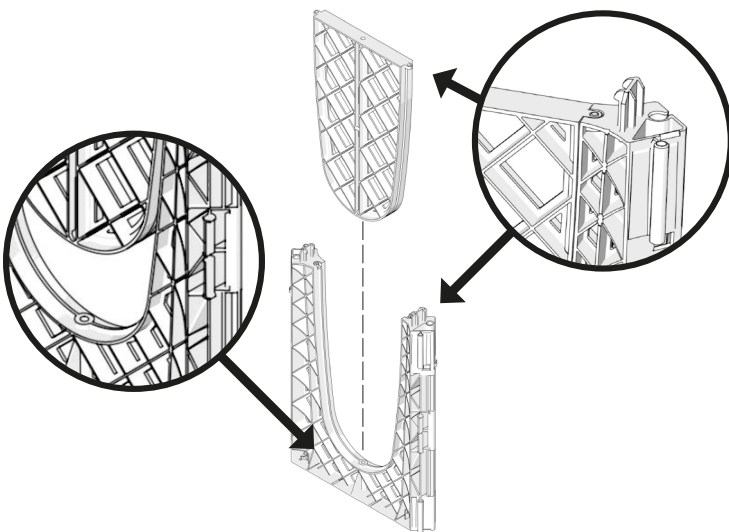

3 Installing AirFlow™ Lid

The AirFlow™ Lid locates on the top tabs and clicks into place.

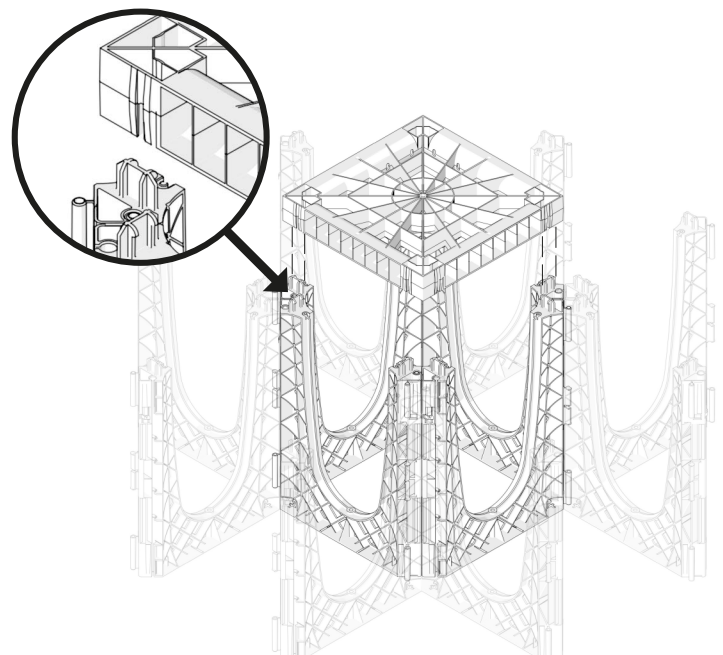

4 Joining two Uprights A together vertically to create multi layered tree pits

To create multi layered tree pits Upright Modules can be joined vertically together.

Only begin assembling the second layer of RootSpace Uprights once the bottom layer is complete.

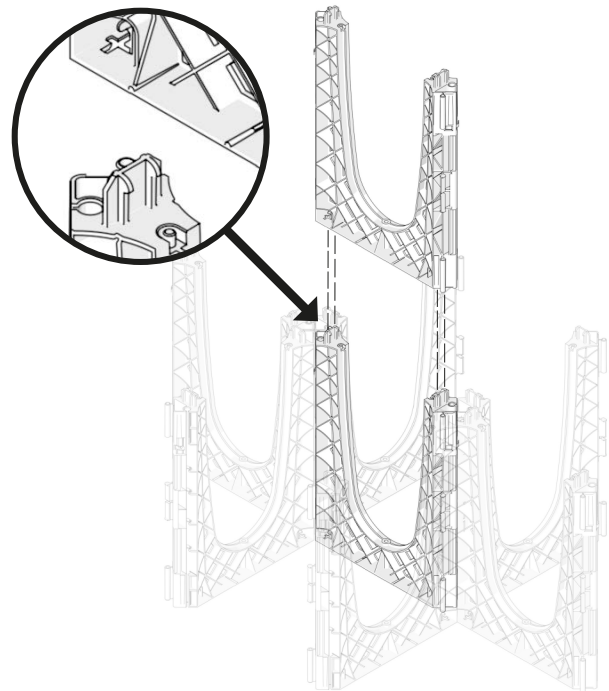

IMPORTANT

Tree pit excavation and setting out RootSpace®

1. Ensure tree pit is adequate size to avoid any side pressure during installation and to prevent distortion of matrix.
2. Before filling with soil, install single row of AirFlow™ Lids along two sides of the tree pit to ensure construction is square.
3. Lay soil to GBU specification in lifts of no more than 10" (250mm), lightly compacting each later by manual treading to achieve 75-80% density.

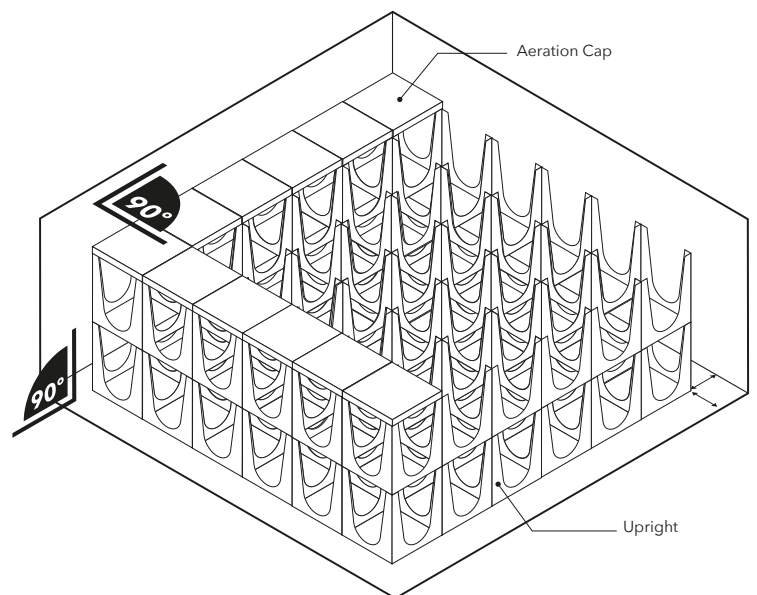

Installation of RootSpace® Pavement Support System

1

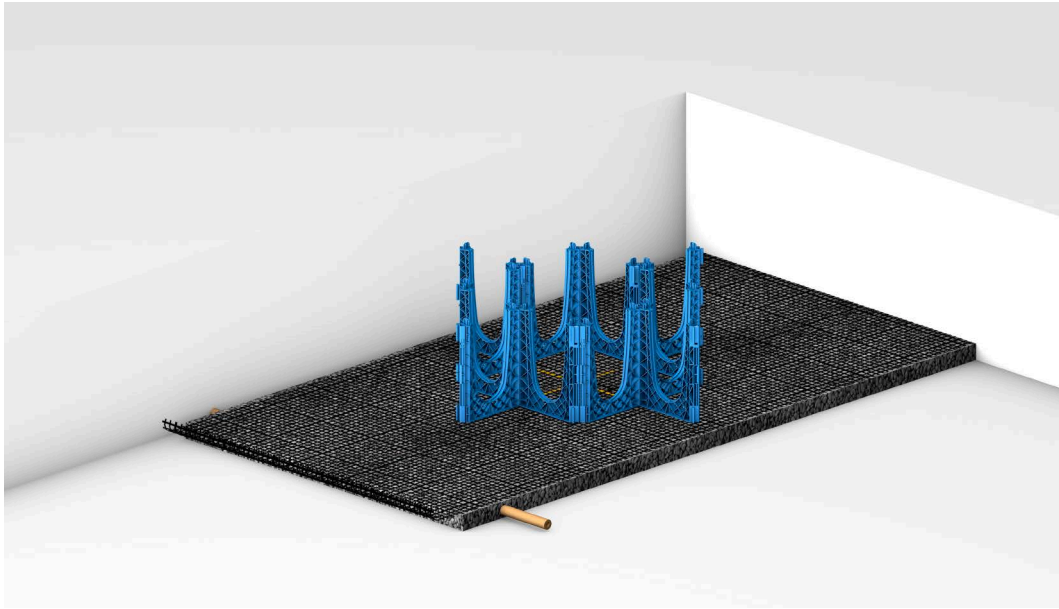

- Begin assembling RootSpace® Uprights around the marked center of the tree pit, working outwards toward the perimeter, ensuring sub-base consistently flat in all directions.

2

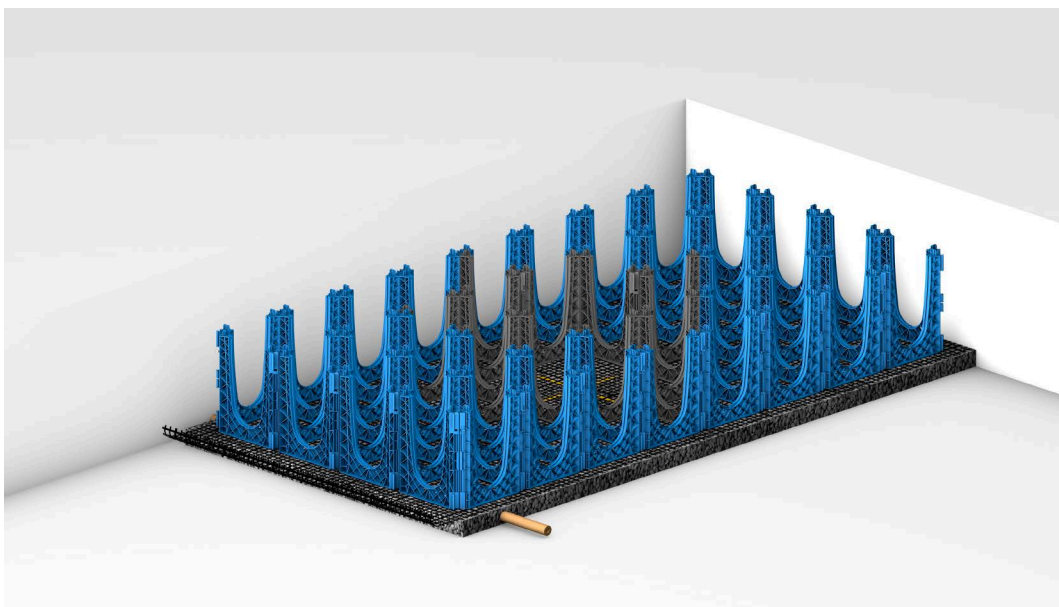

- Continue building out the tree pit Uprights before installing the RootSpace® AirFlow™ Lid around the perimeter of the tree pit. Where a single row of RootSpace® is used, anchor the base of the Upright Panel to the sub-base using a 3/8" x 8" galvanized spiral spike.

3

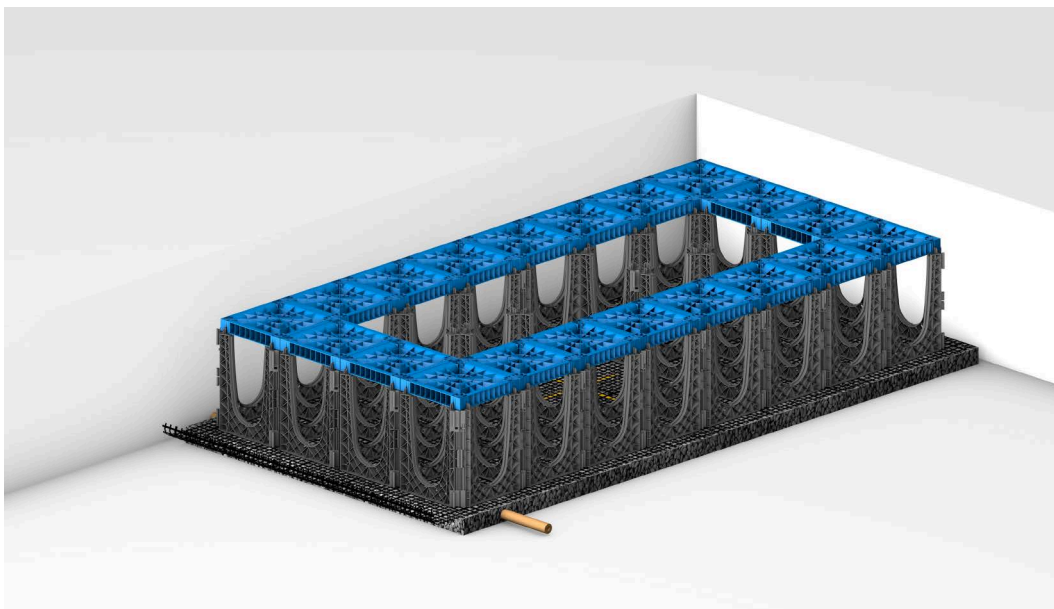

- To allow for easy filling of soil, ladder the remaining RootSpace® AirFlow™ Lids as per the diagram below to ensure structural integrity is retained once filled with soil.

4

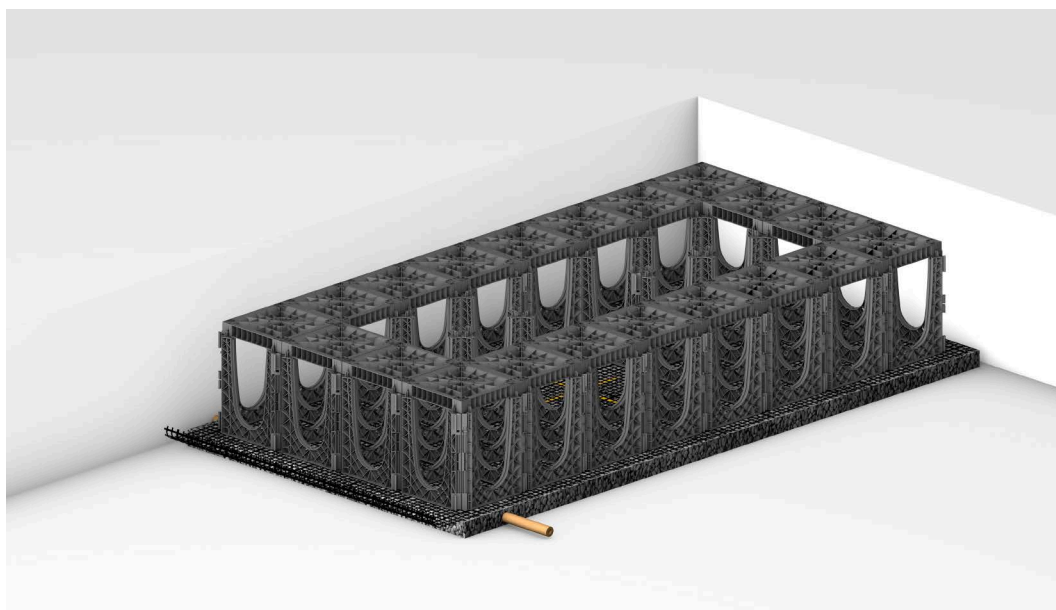

- RootSpace® assembly complete.

GreenBlue Urban Ltd - UK
Northpoint, Compass Park
Bodiam TN32 5BS
United Kingdom

www.greenblue.com
enquiries@greenblueurban.com
Sales and Service: +44 (0)1580 830 800

GreenBlue Urban Ltd - USA
4405 Anderson Road
Knoxville, TN 37918
United States

www.greenblue.com
inquiries@greenblue.com
Sales and Service: 1 866 282 2743

GreenBlue Urban Ltd - Canada
71 Bysham Park Drive
Woodstock, ON N4T 1P1
Canada

www.greenblue.com
inquiries@greenblue.com
Sales and Service: 1 866 282 2743